

Qualified for Automotive Applications

AEC-Q100 Qualified with the Following Results:

- Device Temperature Grade 1: -40°C to 125°C
- Ambient Operating Temperature Range
- Device HBM ESD Classification Level H2
- Device CDM ESD Classification Level C3B

Wide Input Voltage Range: 3.2V-50V

Low Shutdown Current 3.7uA

Low Quiescent operating Current: 450uA

Adjustable Switching Frequency: 100KHz to 2.2MHz

Integrated Frequency Dithering for EMI Mitigation

External Frequency Synchronic

External Compensation

Supports additional Slope Compensation

22ms Internal Soft-start Time

Integrated Protection Feature

- Constant Peak-Current Protection Threshold
- Over Input Voltage
- Output Overvoltage Protection
- Adjust Under-Voltage Lockout
- Optional Hiccup Over Load Protection
- Thermal Shutdown Protection:165°C

MSOP-8L(3mm*3mm) Package

Muti-output Flyback

LED Bias Supply

Portable Speaker Supply

Battery Powered Boost/Flyback/SEPIC application

SCT81620Q

Revision 1.1: Update Device Order Information

ORDERABLE DEVICE	PACKAGING TYPE	STANDARD PACK QTY	PACKAGE MARKING	PINS	PACKAGE DESCRIPTION
SCT81620QMTDR	Tape & Reel	4000	1620Q	8	8-Lead 3mmx3mm Plastic MSOP

Over operating free-air temperature unless otherwise noted⁽¹⁾

DESCRIPTION	MIN	MAX	UNIT
VIN	-0.3	62	V
DR	-1	6.6	V
I _{SEN} , COMP, FB, FA/SYNC/SD	-5	5.5	V
Peak Driver Output Current		1 ⁽²⁾	A
Junction temperature ⁽²⁾	-40	150	C

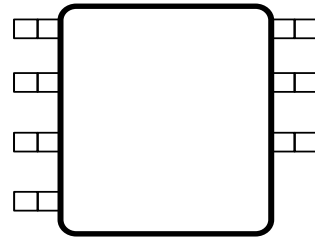

Top View: 8-Lead Plastic MSOP 3mmx3mm

V _{IN}	8	Power supply input pin
-----------------	---	------------------------

Over operating free-air temperature range unless otherwise noted

PARAMETER	DEFINITION	MIN	MAX	UNIT
V _{IN}	Input voltage range	3.2	50	V
V _{CC}	VCC voltage range	3.2	6.1	V
T _J	Operating junction temperature	-40	125	°C

PARAMETER	DEFINITION	MIN	MAX	UNIT
V _{ESD}	Human Body Model(HBM), per ANSI-JEDEC-JS-001-2014 specification, all pins	-2	+2	kV

SCT81620Q

$V_{IN}=12V$, $T_J=-40^{\circ}C-125^{\circ}C$, typical values are tested under $25^{\circ}C$.

SYMBOL

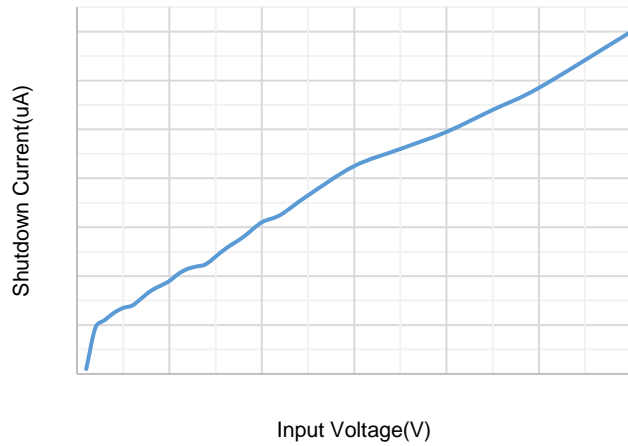

Figure 1. ISD vs Input Voltage

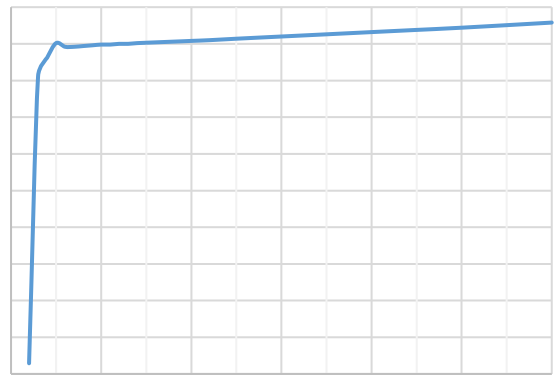

Figure 2. IQ vs Input Voltage

Figure 3. Switching Frequency vs RT

Figure 4. Switching Frequency vs Temperature

Figure 5. Efficiency vs Load Current, Boost, VOUT=12V

Figure 6. Efficiency vs Load Current, Sepic, VOUT=12V

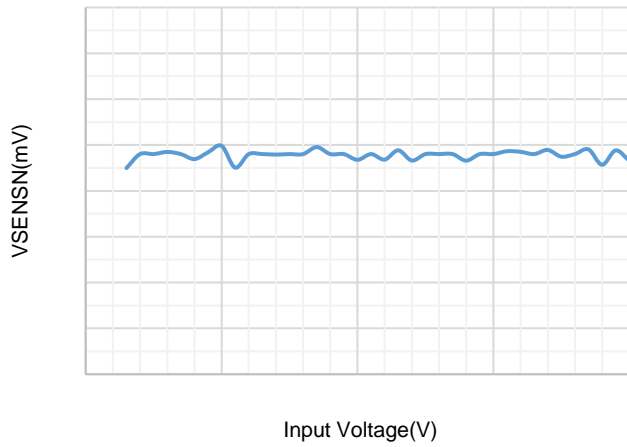

Figure 7. VSENSN vs Input Voltage

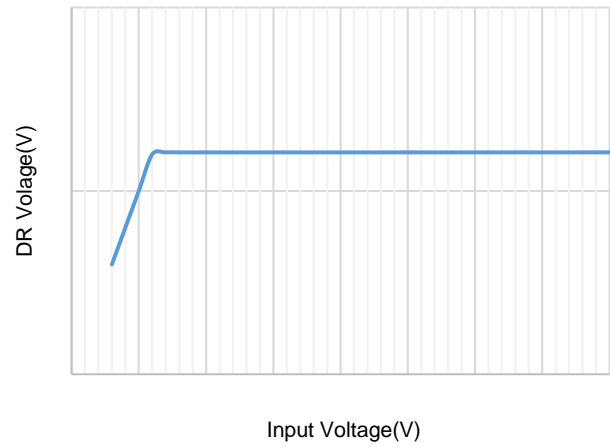

Figure 8. DR Voltage vs Input Voltage

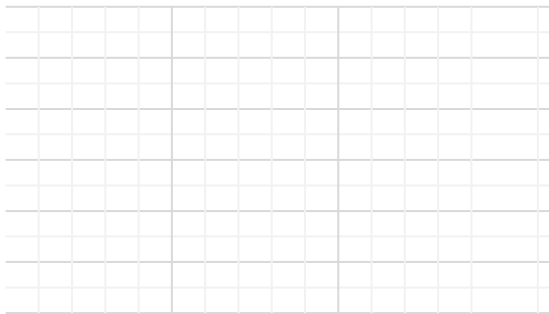

Figure 9. COMP Current vs Temperature

Figure 10. DR Resistance vs Temperature

$$V_{samp} = I_L * R_{SEN} \quad (1)$$

$$M_1 = M_{on} * R_{SEN} \quad (2)$$

$$M_2 = M_{off} * R_{SEN} \quad (3)$$

$$M_1 = M_{on} * R_{SEN} = V_{in} * R_{SEN} / L \quad (4)$$

$$M_2 = M_{off} * R_{SEN} = (V_{out} - V_{in}) * R_{SEN} / L \quad (5)$$

$$V_{samp1} = \left(\frac{M_2}{M_1} \frac{M_c}{M_c} \right) V_{samp0} \quad (6)$$

$$V_{samp1} = \left(\frac{M_2}{M_1} \right) * V_{samp0} = \left(\frac{D}{1-D} \right) * V_{samp0} \quad (7)$$

$$\left| \left(\frac{M_2}{M_1} \frac{M_c}{M_c} \right) \right| < 1 \quad (8)$$

$$M_c = V_{SL} * F_s \quad (9)$$

$$M_c = (V_{SL} - K * R_{SL}) * F_s \quad (10)$$

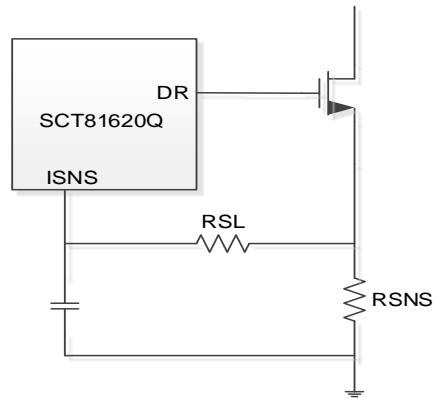

Figure13 .External RSL to increase slope compensation

Adjustable Peak Current Limit

$$I_{PEAK_CL} = \frac{V_{SENSE} \cdot 40\mu A \cdot R_{SL} \cdot D}{R_{SNS}} \quad (11)$$

Where

- VSENSE is ISEN pin limiting voltage (Typ.=146.5mV)
- IPEAK-CL is the inductor peak current limit
- RSL is Slope compensation resistor
- D is Duty cycle
- RSNS is the Inductance peak current detection resistance

SCT81620Q

Output Voltage

$$R_{FBT} \frac{V_{OUT} - V_{REF}}{V_{REF}} R_{FBB}$$

Typical Application (Boost)

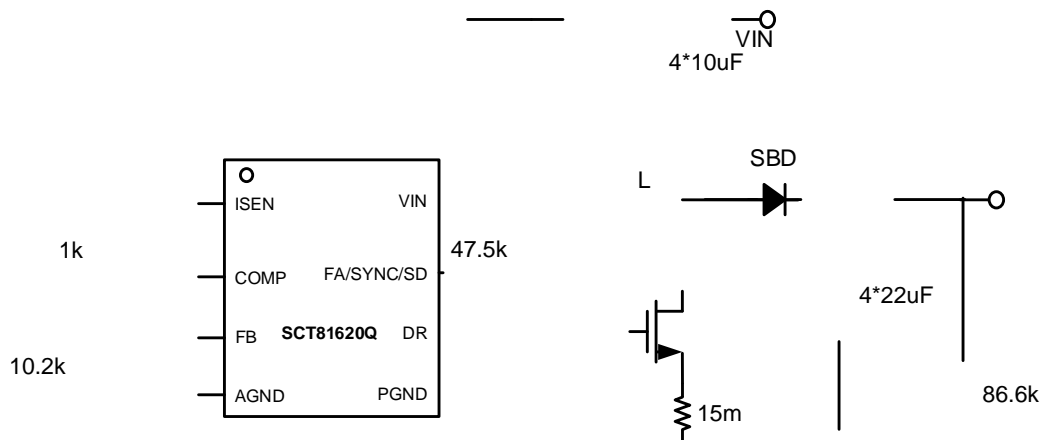

Figure 19. Application Schematic, 3V to 11V, 2A Boost Regulator at 400kHz

Design Parameters

Design Parameters	Example Value
Input Voltage	5V Normal 3V to 11V
Output Voltage	12V
Maximum Output Current	3A
Switching Frequency	400 KHz
Output voltage ripple (peak to peak)	75mV (Load=2A)

Inductor Selection (Boost)

$$= \frac{\times}{\times} \tag{14}$$

Where

V_{OUT} is the output voltage of the boost converter

I_{OUT} is the output current of the boost converter

V_{IN} is the input voltage of the boost converter

$$= \frac{1}{\times \left(\frac{1}{-} + \frac{1}{-} \right) \times} \tag{15}$$

Where

I_{LPP} is the inductor peak-to-

Where

I_G is the gate drive current.

Output Diode Selection

$$I_{D(PEAK)} = \frac{I_{OUT}}{(1 - D)} \quad I_L \quad (24)$$

SCT81620Q

Application Waveforms

Vin=5V, Vout=12V, unless otherwise noted

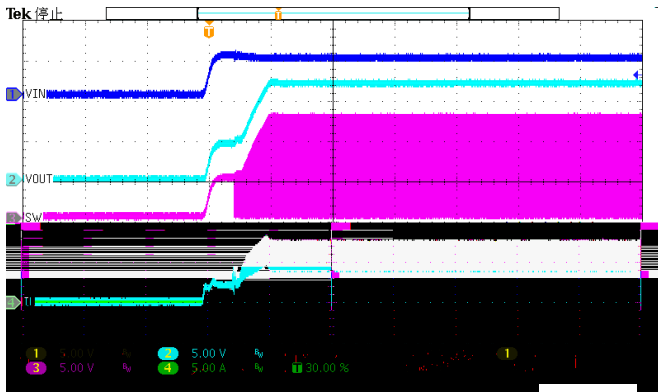

Figure 20. Power up(Iload=2A)

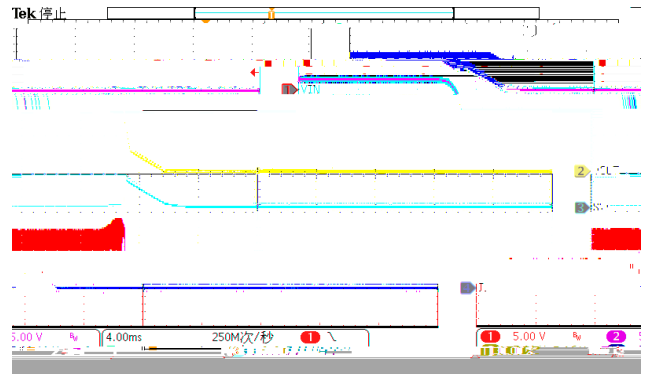

Figure 21. Power down(Iload=2A)

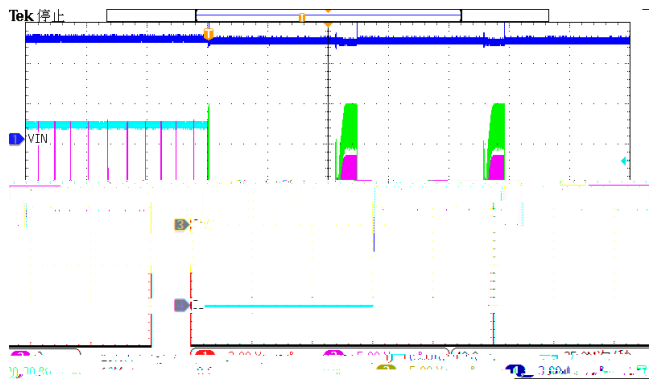

Figure 22. Over current protection (Iload=5A)

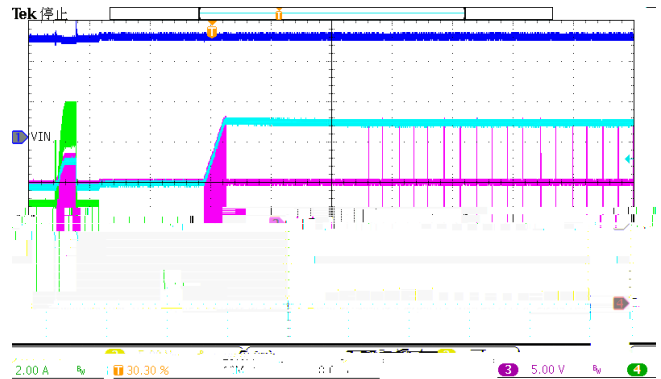

Figure 23. Over current recovery (Iload=5A)

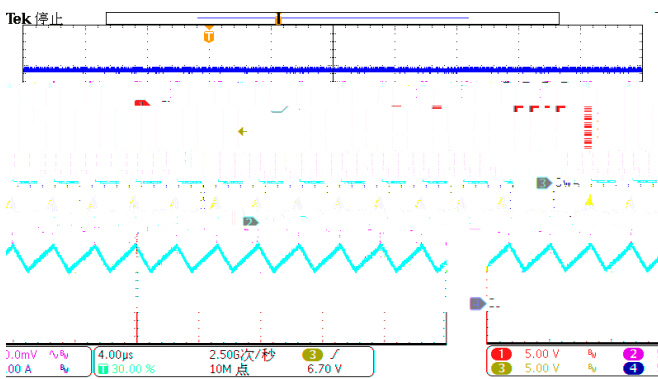

Figure 24. Steady-state (Iload=2A)

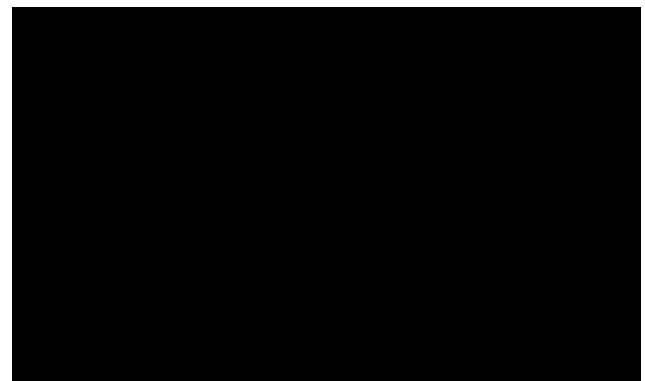

Figure 25. Sync Frequency

Typical Application (Sepic)

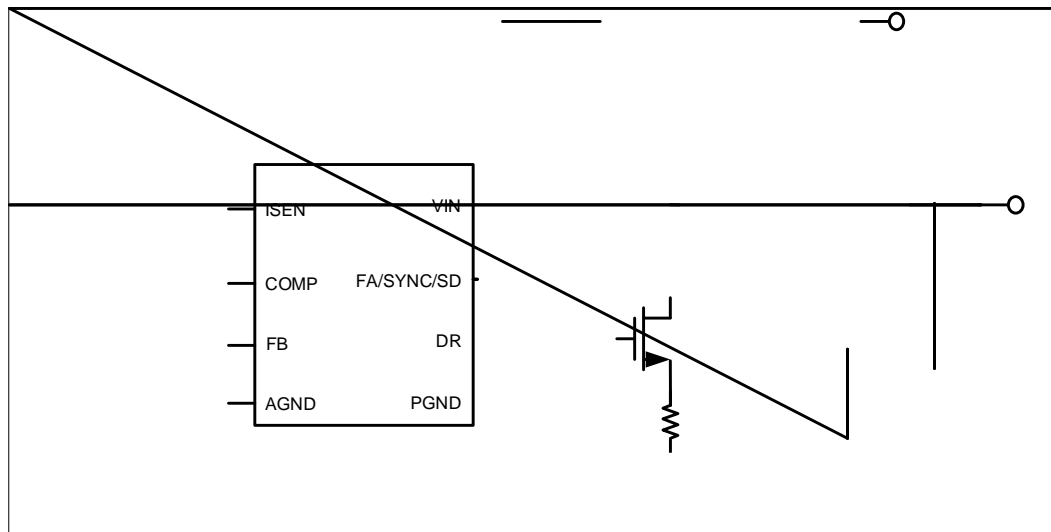

Figure 26. Application Schematic, 5V to 50V, 2A Sepic Regulator at 400kHz

Design

Inductor Selection (Sepic)

$$I_{L1} = I_{IN} \cdot 40\% = I_O \cdot \frac{V_O}{V_{IN_MIN}} \cdot 40\% \quad (25)$$

(26)

$$L = \frac{V_{IN_MIN}}{I_L \cdot f_{SW}} \cdot D_{MAX} \quad (27)$$

f_{SW} is the switching frequency.

$$I_{L1_PEAK} = I_{IN} \cdot \frac{I_L}{2} = I_O \cdot \frac{V_O}{V_{IN_MIN}} \cdot \left(1 + \frac{40\%}{2}\right) \quad (28)$$

$$I_{L2_PEAK} = I_O \cdot \frac{I_L}{2} = I_O \cdot \left(1 + \frac{40\%}{2}\right) \quad (29)$$

$$I_{COUT_RMS} = I_O \sqrt{\frac{D_{MAX}}{1 - D_{MAX}}} \quad (41)$$



Figure 27. Output Voltage Ripple

Application Waveforms

Vin=5V, Vout=12V, unless otherwise noted



Figure 28. Power up(Iload=2A)

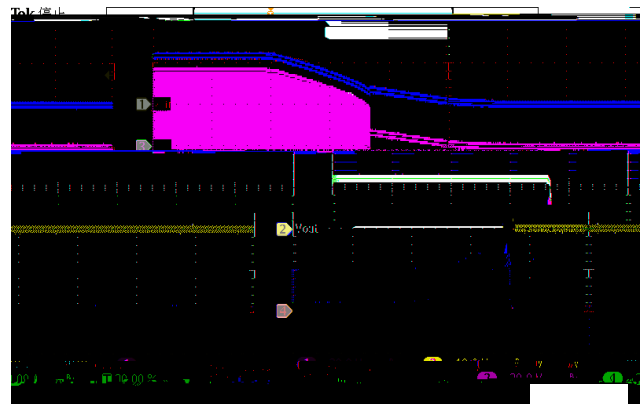

Figure 29. Power down(Iload=2A)



Figure 30. Shutdown remove

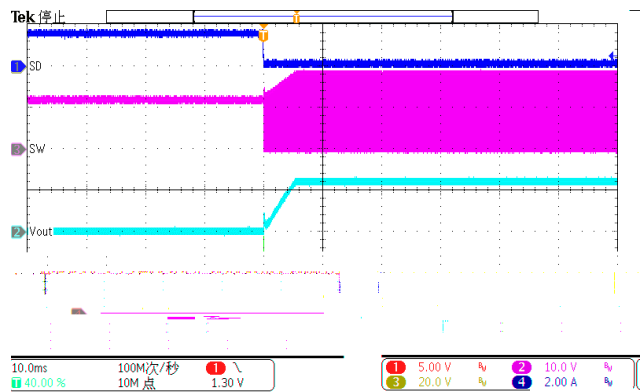

Figure 31. Shutdown remove

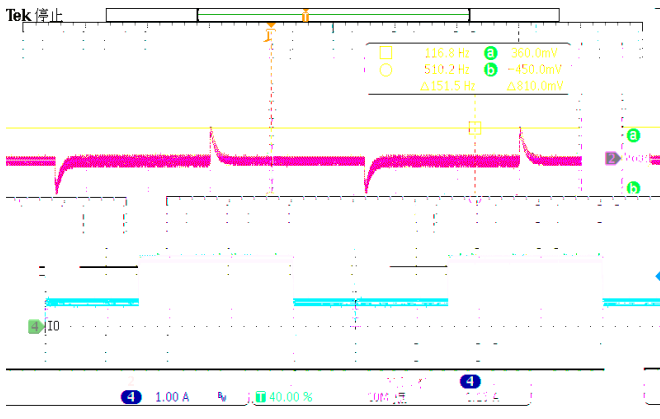

Figure 32. LoadTrans (Iload=0.5A-1.5A)

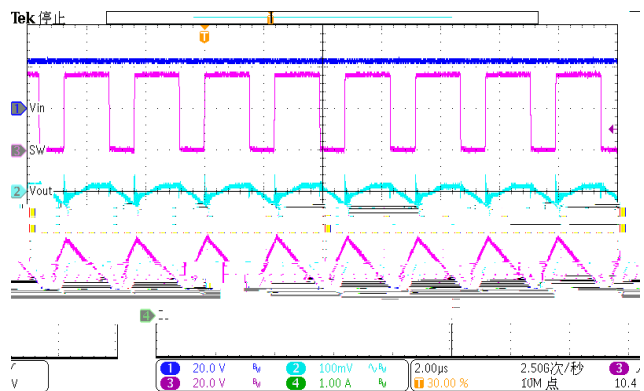

Figure 33. steady-state (Iload=2A)

Layout Guideline

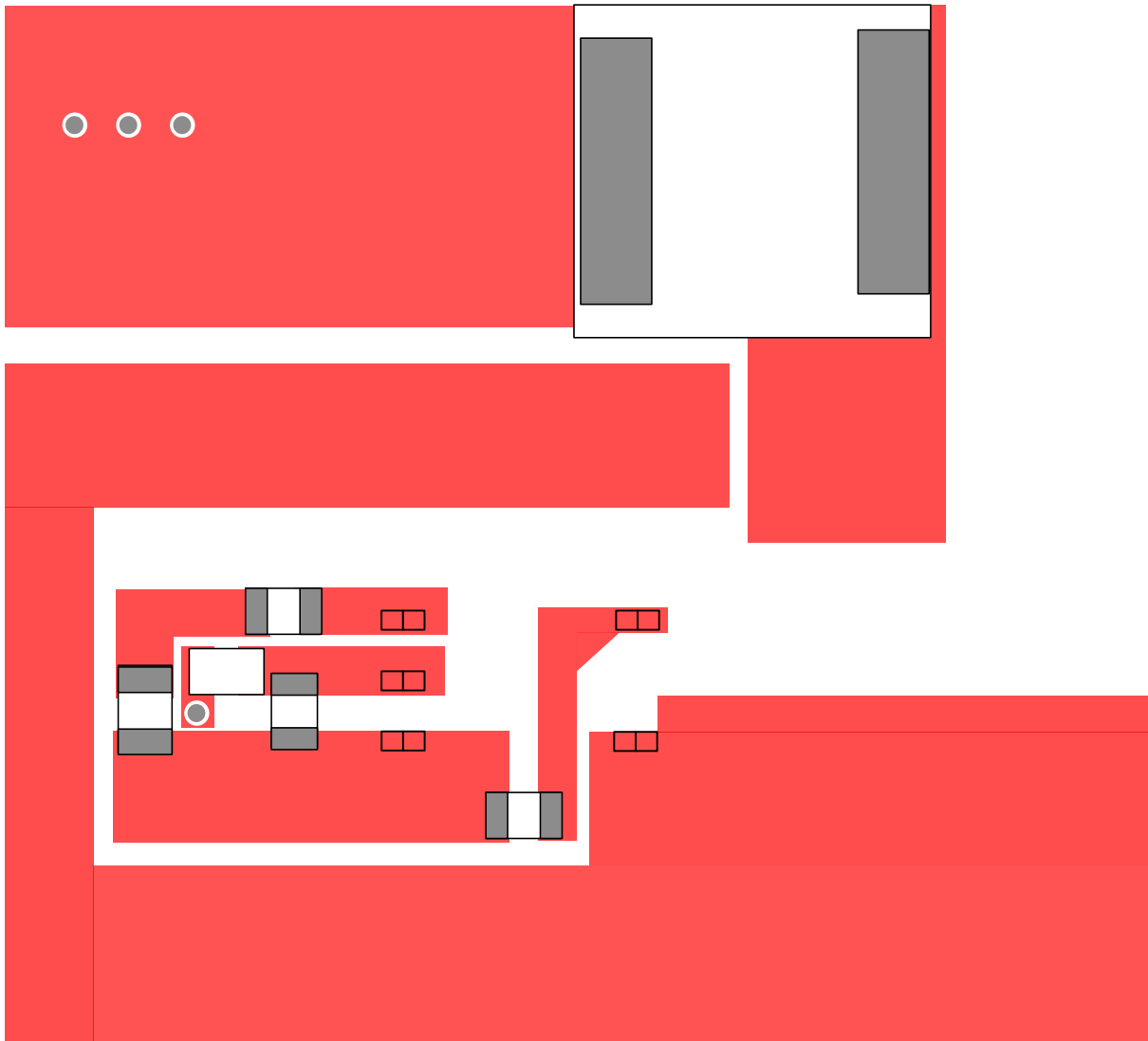
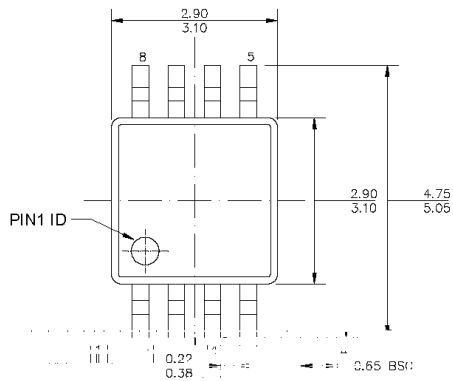
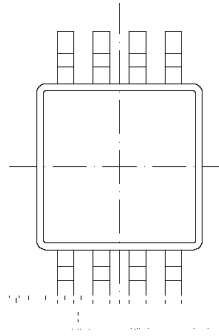

Figure 34. BOOST PCB Layout



TOP VIEW



BOTTOM VIEW

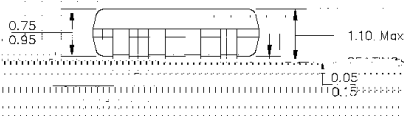

SIDE VIEW

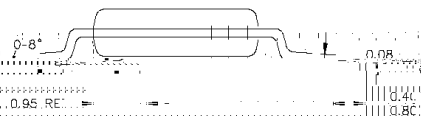

FRONT VIEW

NOTE:

- 1) ALL DIMENSIONS ARE IN MILLIMETERS.
- 2) PACKAGE LENGTH DOES NOT INCLUDE MOUNTING TABS, PROTRUSION OR GAUGE BURR.
- 3) DRAWING METRIC TS REF: C-19-18, VARIATION BA.

RECOMMENDED LAND PATTERN

SCT81620Q

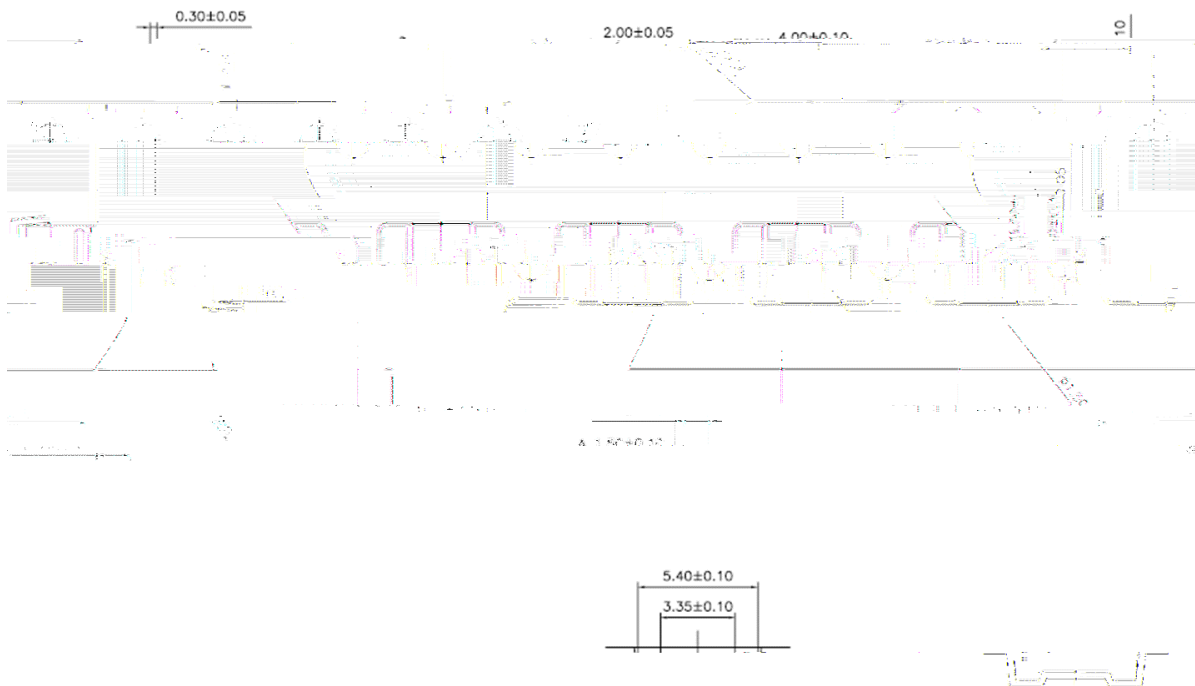

NOTICE: The information in this document is subject to change without notice. Users should warrant and guarantee the third party Intellectual Property rights are not infringed upon when integrating Silicon Content Technology (SCT) products into any application. SCT will not assume any legal responsibility for any said applications.